

**Model 875CR Intelligent Electrochemical Analyzer
 for Contacting Conductivity and Resistivity Measurements**

PANEL MOUNTED
 ANALYZER



FIELD MOUNTED
 ANALYZER

This microprocessor-based, line-powered intelligent analyzer which, when used with Foxboro 871CR or 871CC sensors, provides high accuracy measurement for either contacting conductivity or resistivity. Functions include measurement display, dual analog outputs, dual relay contacts, and an RS-232 Serial Port for remote configuration. A human interface guides the user through intuitive, menu-driven configuration, calibration, status, and troubleshooting procedures.

FEATURES

- ▶ Easy to use.
- ▶ Dual Sensor Input.
- ▶ Exceptional Accuracy and Sensitivity
- ▶ RS-232 Port and Windows-based Configuration Utility.
- ▶ Optional HART Communication Protocol.
- ▶ USP23/24 Compliant.
- ▶ Designed with your industry in mind.
- ▶ Dual Alarms and Dual 4 to 20 mA Outputs.
- ▶ NEMA 4X and IEC IP65 protection for field mounted analyzer, and for front surface of panel mounted analyzer.
- ▶ Single unit for Conductivity or Resistivity.
- ▶ Compatible with 871CR and 871CC Sensors.
- ▶ History log for up to 100 events.
- ▶ On-Line sensor and analyzer diagnostics communicate real-time measurement faults.
- ▶ Secure data and calibrations.
- ▶ Application switching and storage of up to 3 sets of application configurations.
- ▶ Resistivity system accuracy of $\pm 1.06\%$ rms.
- ▶ Remote range and application switching using PLC compatible contact inputs.
- ▶ Complies with EMC Directive 89-336-EEC.

- ▶ Conforms to all applicable European Union Directives (Product Marked with “CE” Logo).

EASY TO USE

The Model 875CR Intelligent Electrochemical Analyzer provides fast and simple installation, configuration, and operation. Input and output wiring is easily accessible. On the field-mounted version, all wiring terminals are accessible through a removable, front-facing cover. On the panel-mounted version, wiring terminals are directly accessible from the rear of the analyzer without removing any covers.

A large, backlit Liquid Crystal Display (LCD) with intuitive menu navigation and on-screen help makes configuration easy and less prone to error. Users have a choice of either **basic** or **advanced** configuration, depending on their needs. **Basic** configuration provides access to only the most commonly changed parameters, greatly simplifying the procedure. **Advanced** configuration, which is protected by a different passcode than **basic**, allows for complete configuration by authorized personnel. Prior to accepting a new configuration, the analyzer performs complete parameter dependency checking, and informs the user of any conflicting or offending parameters. The analyzer then brings the user to the parameter(s) in question, and prompts the user to review the selection(s) that should be altered.

Calibration routines are also intuitive and menu-driven. Users are offered a choice of electronic or solution calibration routines, depending on user preference and measurement mode (conductivity or resistivity). In all situations, the user may implement a default calibration with the push of a button, restoring the instrument to a factory calibrated condition for the measurement range of interest.

For the ultimate in ease of use, the analyzer is available with an optional Windows-based PC configuration utility that utilizes the built-in RS-232 serial communication port. More information on this feature is located further in this document.

DUAL SENSOR INPUT

Either one or two contacting type sensors can be connected to the Analyzer. When two sensors are connected, the user may configure the analyzer in one of two (2) modes, either **dual** or **redundant**.

Dual Sensor Mode — Each sensor may be configured and calibrated individually. The user may then utilize the two sensor signals in a number of different ways. For example, the two sensors may be used to monitor water quality in two different locations. Each sensor configuration may include unique cell factor, range, temperature compensation type, etc. The two sensors need not have the same nominal cell factor. Thus, in a water purification process, where the upstream water may require a 10.0 cm^{-1} cell factor sensor, and the downstream water a 0.1 cm^{-1} cell factor, the analyzer can easily be programmed to accommodate this application. Another way to utilize the two sensor signals is through mathematical manipulation, yielding configurable parameters of % rejection, ratio, average, and difference. For any of the configurations discussed, the analyzer affords the user ultimate programmability relative to displayed parameters, alarm settings, and outputs.

Redundant Sensor Mode — In this mode the user designates one sensor as **primary**, and the other as **backup**. Though the two sensors are calibrated individually, the application is the same for each. Thus there is one measurement range, one temperature compensation type, one nominal cell factor, etc. The primary benefit of redundant configuration is extra security for highly critical applications. If the **primary** sensor measurement becomes suspect, or if the sensor fails outright, the **backup** sensor can then take over without the need to break the process line. The switchover from primary to backup sensor can be performed manually or automatically. When configured to switch automatically, the criteria for switchover are sensor faults of open or short RTD, or liquid leakage into the sensor body.

Additionally, in the **redundant** mode, the **primary** and **backup** sensor signals can be compared for difference or average, and an alarm set accordingly.

RS-232 PORT AND WINDOWS-BASED CONFIGURATION UTILITY

Every 875CR Analyzer is manufactured with a built-in RS-232 port. This non-isolated port can be connected to simple printers and terminals for continuous display of measurement data.

When used with the optional Windows-based configuration utility, the instrument can be addressed from a standard PC, providing easy implementation of the following functions:

- ▶ View Measurement Data
- ▶ View Analyzer Status Data
- ▶ Perform Analyzer Configuration
- ▶ Upload Configuration Data from Analyzer
- ▶ Download Configuration Data to Analyzer
- ▶ Perform System Calibration
- ▶ View Sensor and Analyzer Diagnostics
- ▶ Place the Analyzer on Hold
- ▶ Download Firmware to Analyzer

The RS-232 port is user configurable for baud rate, update time, data and parity, and stop bits.

HIGH ACCURACY, WIDE RANGEABILITY

Highly accurate measurements are provided by the combination of the 875CR Analyzer and a Foxboro 871CR Sensor. Resistivity ranges are selectable from 0.2 k Ω •cm through 20 M Ω •cm (temperature-corrected); conductivity ranges are selectable from 0 to 1 μ S/cm through 0 to 20 mS/cm (temperature corrected). Absolute conductivity measurement ranges are approximately five times greater. Range selection can be made from the integral keypad, or via the optional Windows-based PC configuration utility.

Refer to section further in this document entitled "System Accuracy of the 875CR Analyzer and 871CR-B Sensor for Resistivity Measurement."

CHOICE OF DIGITAL COMMUNICATIONS

The 875CR Analyzer provides maximum flexibility of digital communications. The basic instrument, with two printed wiring assemblies (PWAs), provides two analog outputs and a built-in RS-232 serial port. For users who require digital communication, a third (optional) PWA for HART Communication Protocol provides connection between the analyzer and host. This PWA can be installed in the basic analyzer, or can be installed in the field at a later time.

The optional HART PWA contains nonvolatile memory, which allows the module to store its unique communication configuration parameters. Functions available via the digital communication option include:

- ▶ View Measurement Data
- ▶ View Analyzer Status Data
- ▶ Perform Analyzer Configuration
- ▶ Upload and Download Configuration Data
- ▶ Perform System Calibration
- ▶ View Sensor and Analyzer Diagnostics
- ▶ Place the Analyzer on Hold

SINGLE UNIT FOR EITHER CONTACTING CONDUCTIVITY OR RESISTIVITY

Each Analyzer is configurable for either contacting conductivity or resistivity. This feature is important for OEM customers and systems integrators who supply systems for water purification. Depending on the technology used to purify water, and the specifications of the treated water, either conductivity or resistivity measurements (or both) might be required. Also, this feature minimizes spares inventory for instruments used as loaners or replacements for equipment supplied to end users.

DESIGNED WITH YOUR INDUSTRY IN MIND

Though most industrial facilities utilize either contacting conductivity or resistivity instrumentation for their pure and ultrapure water monitoring needs, the specific requirements vary from industry to industry. 875CR Analyzer is designed to meet your needs. Listed below are a few examples of Industry applications.

Power Industry Applications

- ▶ Special Temperature Compensations for Cation Conductivity, Ammonia, Morpholine
- ▶ Dual Sensor Input for Demineralizer Bed Monitoring

Semiconductor Industry Applications

- ▶ Hallmark System Accuracy for Ultrapure Water Resistivity Measurements

Pharmaceutical Industry Applications

- ▶ Exceeds USP23/24 Requirements (Table 1) (USP = United States Pharmacopoeia)
- ▶ Dual Sensor Input with Redundant Mode Operation allows Dynamic Switchover to a Backup Sensor without breaking Process Line

Pulp and Paper, Chemical, Metal and Mining Industry Applications

- ▶ Rugged and Reliable for Condensate and Feedwater Monitoring

Food and Beverage Industry Applications

Sensitive and Accurate Measurement of Process Feed Water and Cleaning Water

COMPATIBLE WITH 871CR AND 871CC SENSORS

For optimum performance and ease of use, the Foxboro 871CR Series Sensors (see Figure 1) are recommended. When a complete loop (analyzer plus sensor) is required, 871CR Sensor is highly recommended. However, the installed base of 871CC sensors is very large, considering they were utilized on several previous models of conductivity and resistivity analyzers, including Models 870, 872, 873, and 874. Therefore, the 875CR Analyzer was designed for compatibility with 871CC Sensors, and is able to replace an existing installation of Model 870, 872, 873, or 874 instruments without changing sensor inventory.

Compatibility with 871CR and 871CC sensor types is achieved through programmable configuration of cell factor and temperature compensator parameters. The analyzer accepts temperature inputs from a 2-wire, 100 Ω RTD, a 3-wire 1000 Ω RTD, and from a 100 k Ω thermistor.

USP23/24 COMPLIANT

The 875CR Intelligent Electrochemical Analyzer meets all operating requirements for USP23/24. Table 1 illustrates the details.

Figure 1. Foxboro 871CR and 871CC Series Sensors

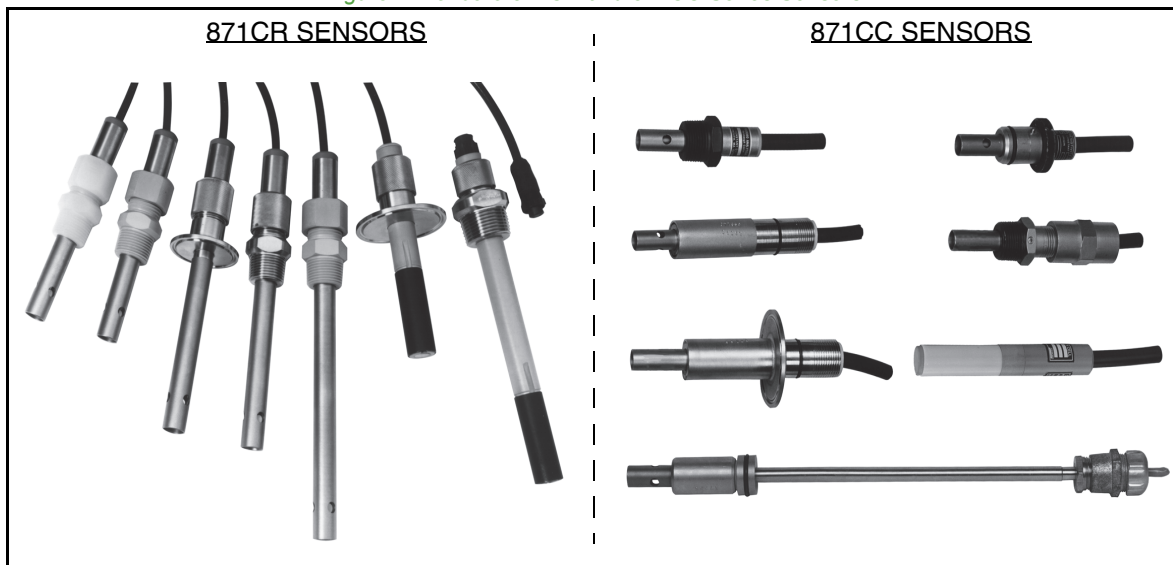

Table 1. Comparing USP23/24 Requirements with 875CR Analyzer and 871CR Sensor Specifications

Specification	USP23/24 Requirement	875CR Analyzer and 871CR Sensor Specifications
Cell Constant Accuracy	± 2%	871CR 1% nominal. NIST traceable calibration certificates are available.
Instrument Resolution at 1.3 µS/cm	0.1 µS/cm	With full scale set at 2.000 µS/cm, resolution is 0.001 µS/cm. With full scale set at 10.00 µS/cm, resolution is 0.01 µS/cm.
Instrument Accuracy	± 1.0%	±0.1%
Instrument Dynamic Range	10 ²	10 ³
Temperature Compensation	Must be read uncompensated	Analog outputs and alarms can be programmed for either uncompensated or compensated conductivity. Compensated conductivity is based upon published USP23/24 Stage 1 table limits.
Instrument Calibration	0.1%	±0.1% or better
Instrument Calibration Requirement	NIST traceable 0.1% precision resistors instead of sensor	Our automatic calibration equipment utilizes NIST traceable calibration standards for calibration of measurement and temperature circuits. Those standards have an accuracy which ensures a calibration ratio of 4:1 or higher, and validate each instrument's measurement calibration to within the stated +/- 0.1% of full scale accuracy. All equipment used in quality control is systematically maintained and calibrated in compliance with ISO 9001 standards. Calibration certificates with serialization are available (specify CERT-E).
Conductivity Sensor	Verify that cell constant is within 2% using ATSM D1125-95 KCl and compare against a "certified" reference	Standard Foxboro 871CR sensors are manufactured to meet 1% specifications, and are then tested according to these standards. Actual cell factors are determined within ±0.1% accuracy and stamped on each sensor cable for each individual cell. Entering these values into the analyzer calibrates the system; thus 871CR sensors exceed USP23/24 requirements. Calibration certificates with serialization are available (specify Model Code Option "-S" on the 871CR Sensor).

DUAL ALARMS AND DUAL 4 to 20 mA OUTPUTS

Two independent, isolated alarm relays are standard. Either alarm is configurable as **off** (nonfunctional) or **on**. When **on**, the alarm is configurable to go **active** (energize relay), or **inactive** (de-energize relay), while passing above or below a measurement setpoint. Each alarm may also be programmed for either hysteresis control, or control based on timing for trigger, on and off. Two front panel LEDs indicate when in alarm.

There are also two independent, isolated 4 to 20 mA analog outputs that are standard. When the optional HART communications PWA is installed, the standard output #2 becomes disabled, and the HART output becomes the second analog output.

The alarms and outputs are each configurable to any of the following parameters:

- ▶ Primary Measurement of either Sensor
- ▶ Absolute Measurement of either Sensor
- ▶ Temperature of either Sensor
- ▶ % Rejection
- ▶ Ratio of Primary Measurements
- ▶ Average of Primary Measurements
- ▶ Difference of Primary Measurements
- ▶ Difference of Temperature

Additionally, the alarms can also be configured to “trip” based upon:

- ▶ Analyzer in Hold
- ▶ Analyzer Fault, Communication Fault, Sensor Fault, Out-of-Range Fault

HISTORY LOG

End users' compliance to ISO⁽¹⁾, GMP⁽¹⁾, and other quality and validation systems are enhanced by the Model 875CR's history log function.

The history log contains up to 100 time and date stamped reported errors, faults, and system-related events. Examples of entries in the history log are:

- ▶ Entry Into and Exit From Configuration, Calibration and Hold Modes
- ▶ Changes to Configuration, Calibration, and Hold

- ▶ Analyzer Power Restored after Outage
- ▶ Passcode Changed
- ▶ Application Switch
- ▶ Alarm 1 or Alarm 2 Activated
- ▶ Switch-over from Primary to Secondary Cell
- ▶ Errors Temporarily Cleared
- ▶ Sensor Faults
- ▶ Analyzer Faults

Contents of the history log can be printed on demand by utilizing the standard RS-232 port.

MOUNTING FOR EITHER FIELD OR PANEL APPLICATIONS

Two distinct analyzer housings are offered to meet your application needs.

For **field mounted** (surface or pipe mounting) use, the analyzer is housed in a tough, epoxy-painted, cast aluminum enclosure able to withstand the harshest field conditions. This enclosure provides the environmental and corrosion-resistant protection of NEMA 4X, CSA Enclosure 4X, and IEC IP65. All input/output wiring is accessible from the front of the instrument through a dedicated field compartment. The terminal connections within this compartment are accessed by simply removing a front cover.

For **panel mounted** applications, a molded plastic enclosure with minimal depth behind the user's panel, saves space, is light weight, and reduces cost. Direct access (no cover) to the wiring terminals is available from the rear of the instrument. This version is rated NEMA 1; however, the front panel meets NEMA 4X requirements when attached to the user's panel, and gasketed in place with the supplied gasket.

Both field and panel mounted units have large spade lug terminals for sensor connections to facilitate installation, calibration, and maintenance. Either unit can also be provided with an optional Plexiglas storm door to prevent accidental activation of the front panel controls, and for dust and hose-down protection. See “Dimensions-Nominal” section for mounting and dimensional information.

1. ISO = International Standards Organization; GMP = Good Manufacturing Practice.

SENSOR AND ANALYZER DIAGNOSTICS

When used with Foxboro 871CR or 871CC Sensors, the analyzer provides sensor diagnostics, including liquid leakage into the sensor body and failure of the temperature compensation element.

In addition, the analyzer performs continuous health checks on its own circuits. Firmware diagnostics include checksum and EEPROM on power-up, code space checksum and CRC on power-up (and approximately every five minutes thereafter), and continuous stack checking and watchdog timer.

For additional information about the specific fault(s), the user need only access the "DIAG" menu and follow the prompts. This procedure not only identifies specific faults, but also guides the user to corrective action without referring to an instruction book.

SECURE DATA AND CALIBRATIONS

Three security levels guard against unauthorized configuration/calibration changes, loss of data, and/or invalid measurement signals. The first passcode permits access to routine maintenance, including calibration and basic output hold. The second passcode permits changes to all first level parameters, plus advanced output hold and basic configuration. The third passcode permits changes to all second level parameters, plus advanced configuration and all passcode changes.

Data stored in EEPROM obviates need for battery backup. Measurement loop security is enhanced by a user programmable "fail signal" parameter activated by analyzer faults and any enabled sensor faults. This "fail signal" parameter forces the analyzer output to any user-defined value between 3.8 and 20.5 mA.

HUMAN INTERFACE

The local Human Interface allows configuration, calibration, status, and fault location without the need of a hand-held terminal. This interface consists of MODE Indicators, a 2-line Display area, a Bargraph Display, two Alarm Indicators, MODE and ENTER keys, LEFT and RIGHT arrow keys, and UP and DOWN arrow keys. The backlighted measurement display characters are 15 mm (0.6 in) high to allow easy reading from a distance. See Figure for the Human Interface configuration, and Table 2 for a description of the indicators and controls.

The display area shown in Figure 2, in addition to indicating measurement data, is also used to display various screens. Figures 3 and 4 show the display area with a configuration screen and a status screen, respectively.

Figure 2. Human Interface Layout

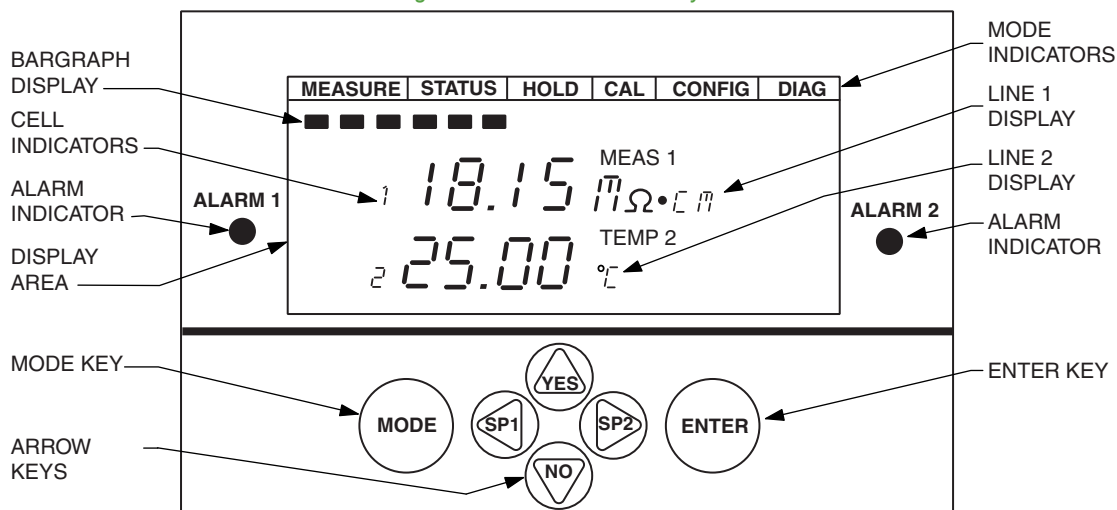

Figure 3. Configuration Screen

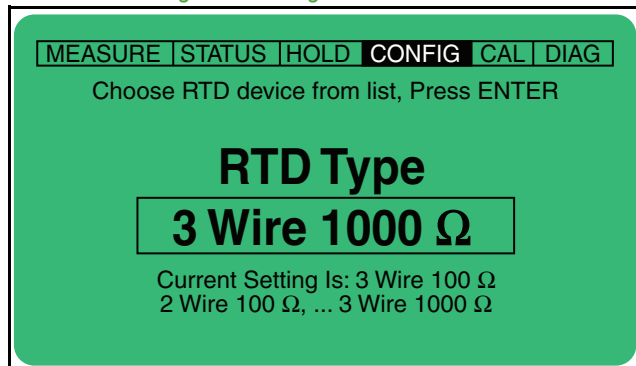

Figure 4. Status Screen

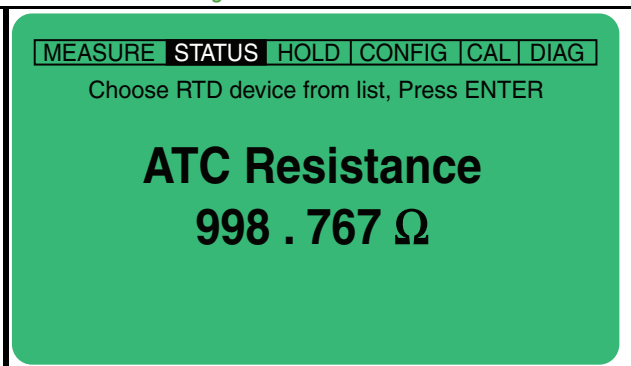

Table 2. Human Interface Indicators and Controls

Control/Indicator	Function
MODE Indicators	The current operating mode indicator is illuminated. While in Hold mode, the Hold indicator blinks.
DISPLAY Area <ul style="list-style-type: none"> ▶ Bargraph ▶ Line 1 ▶ Line 2 	<p>The display is a graphic panel that shows information in combinations of alphanumeric and special characters, and a decimal point.</p> <ul style="list-style-type: none"> ▶ Displays percent-of-range of the Line 1 value on the display. ▶ Displays measurements in Measure mode. ▶ Displays measurements in Measure mode.
ALARM Indicators	Alarm 1 (Alarm 2) indicator is illuminated when Alarm 1 (Alarm 2) is active.
MODE Key	Each press of the Mode key selects the next operating mode (Measure, Status, Hold, Calibrate, Configure, and Diagnostic).
RIGHT Arrow Key	<ul style="list-style-type: none"> ▶ Moves you forward through the menu structure. ▶ Shifts the cursor to the right in a data entry field. ▶ Offers a "short cut" to the Alarm 2 set point when in Measure mode.
LEFT Arrow Key	<ul style="list-style-type: none"> ▶ Moves you backward through the menu structure. ▶ Shifts the cursor to the left in a data entry field. ▶ Offers a "short cut" to the Alarm 1 set point when in Measure mode.
UP Arrow Key	<ul style="list-style-type: none"> ▶ Increments a numeric value or character when in a data entry field. ▶ Shifts the items down when in a picklist menu. ▶ Answers Yes to a question.
DOWN Arrow Key	<ul style="list-style-type: none"> ▶ Decrements a numeric value or character when in a data entry field. ▶ Shifts the items up when in a picklist menu. ▶ Answers No to a question.
ENTER Key	Enters and saves the changed menu picklist choices or numeric value or character data entry.

CUSTOMIZE AND EMPLOY UP TO THREE APPLICATIONS

This unique feature allows the user to preconfigure the analyzer for up to three distinct applications. Each application may have its own range, temperature compensation curve, chemical concentration curve (if applicable), and output configuration. Each application is assigned a number, for example, application 1, application 2, or application 3. If the user wishes to switch from one application to another, the user simply changes one parameter in the configuration menu and the entire application set switches in automatically. This is a powerful feature for users who frequently change among a handful of common recipes.

In many cases, the user will want the analyzer to auto-switch from one application to another without user intervention. This can be accomplished in two ways, either through auto-switching based on predetermined percent-of-range switch points, or through a command from an external host (e.g., PLC) to a series of digital inputs, each dedicated to a specific application set. Each method of auto-switching is described in the paragraphs that follow.

Auto-Switching Using Switch Limits

User-programmable switch limits determine when the analyzer auto-switches from application 1 to application 2, then again from application 2 to application 3. Similarly, the analyzer auto-switches in a descending fashion depending on the low percent-of-range switch programmed by the user.

Auto-Switching Using Digital Inputs

Each 875CR Analyzer provides 4 digital inputs, 3 of which are dedicated to application sets – input 1 for application 1, input 2 for application 2, etc. If a PLC is controlling a particular process (Clean-In-Place for beverage, dairy, etc., for example), the user can program the PLC to command the 875CR to switch to a specific application based on time or process control parameters such as temperature, concentration, conductivity, etc.

Because each of the applications (three maximum) is individually configured, calibration constants are stored in memory and invoked as the application is retrieved. Thus, the analyzer can switch from a wide range conductivity application to a very sensitive one without the need to recalibrate the system for the new range. This results in tremendous time savings for operators, and eliminates common sources of error in critical applications.

OPERATING, STORAGE, AND TRANSPORTATION CONDITIONS

Influence	Reference Operating Conditions	Normal Operating Conditions	Operative Limits	Storage and Transportation Limits
Ambient Temperature	23 ±2°C (73 ±4°F)	-10 to + 65°C (a) (14 to 149°F)	-20 and +75°C (a) (-4 and +165°F)	-40 and +85°C (-40 and +185°F)
Relative Humidity	50 ±10%	5 to 95% Noncondensing	5 and 95% Noncondensing	5 and 95% Noncondensig
Supply Voltage, ac (b)	Rated Voltage ±1%	Rated Voltage -15 to +10%	Rated Voltage -20 and +15%	Not Applicable
Supply Frequency, ac	50 or 60 Hz, ±1%	50 or 60 Hz, ±3 Hz	50 and 60 Hz, ±3 Hz	Not Applicable
Supply Voltage, dc	24 V dc, ±1%	19.2 to 33.6 V dc	18 to 36 V dc	Not Applicable
Vibration - Std. Constr. ▶ Field Mount ▶ Panel Mount	▶ 1 "g" (10 m/s ²) between a frequency of 5 and 200 Hz ▶ 0.25 "g" (2.5 m/s ²) between a frequency of 5 and 200 Hz			Note (c)
Vibration - (d) Rugged Construction	Vibration qualified per MIL Std. 167-1 for use as a Navy shipboard device.			Note (c)
Mechanical Shock - (d) Rugged Construction	Mechanical shock qualified per MIL Std. S-901; Grade A, Class I, Type C, for use as a Navy shipboard device.			Note (c)
Pollution Degree	3, per ANSI/ISA S82.01			Not Applicable
Installation Category (Overvoltage Category)	II, per ANSI/ISA S82.01			Not Applicable
Mounting Position	Generally Upright	Any Position	Any Position	Not Applicable

- a. Refer to the Electrical Safety Specifications section for a restriction in ambient temperature with certain electrical certifications.
- b. Rated Voltage is 24, 100, 120, 220, or 240 V ac, 50 or 60 Hz. See Model Code section.
- c. During transportation, the packaged Analyzer can withstand normal handling and shipping conditions without damage.
- d. Rugged construction is only available with Field Mount Analyzers.

PERFORMANCE SPECIFICATIONS

Analyzer Specifications under Reference Operating Conditions unless otherwise specified. Refer to Sensor Literature for Sensor Specifications.

Accuracy - Digital Output

±0.1% of full scale

Accuracy - Analog Output

Digital accuracy ±0.05% of full scale

System Accuracy with Resistivity Measurement

±1.06% rms. Also see "System Accuracy of the 875CR Analyzer and 871CR Sensor for Resistivity Measurement" section that follows.

Accuracy - Temperature (Includes Repeatability)

Sensor Description	Accuracy
2-wire, 100 Ω, Plat. RTD(a)	±0.2°C (±0.36°F)
2-wire, 100 k Ω Thermistor (a)	±0.2°C (±0.36°F)
3-wire, 1000 Ω, Plat. RTD	±0.03°C (±0.05°F)

- (a) 2-wire platinum RTD and 100 k Ω thermistor have been corrected for cable length.

Stability**Primary Measurement**

±0.25% of full scale (temperature-compensated and after six months)

Temperature Measurement

±0.1% of full scale (noncumulative and after six months)

Repeatability

±0.1% of full scale

Response Time**Primary Measurement**

3 seconds or better, depending on configuration

Temperature Measurement

<10 seconds, 2- or 3-wire temperature sensor

Output Noise (Analog Outputs)

±0.25% of span (measured with a 500 Hz bandwidth)

Ambient Temperature Effect**Digital Measurement**

±0.05% of span per °C

Analog Output

±0.05% of span per °C

Vibration Effect (Sensor not included)

Less than 0.1% of span

Mounting Position Effect

Less than 0.01% of span for all positions.

Relative Humidity Effect**Digital Measurement**

±0.5% of span, from 50 to 95% RH at 40°C.

Analog Output

±0.5% of span, from 50 to 95% RH at 40°C.

Power Supply Effect

±0.5% of span for a +10% voltage shift

±0.75% of span for a -15% voltage shift

±0.1% of span for a 3 Hz shift at 50 or 60 Hz

Output Load Effect

<0.05% of span value; effect is on output for a change in loop resistance of up to 800 Ω .

European Union and International Directives

- ▶ Complies with Electromagnetic Compatibility Requirements of European EMC Directive 89/336/EEC by conforming to the following CENELEC and IEC Standards: EN 50081-2, EN 50082-2, and IEC 61000-4-2 through 61000 4-6.
- ▶ Complies with NAMUR Part 1 Interference Immunity Requirement (EMC).
- ▶ Conforms to Applicable European Union Directives ("CE" marking on product).

CFI Immunity⁽²⁾

10 V (rms) from 0.15 to 80 MHz with 80% amplitude modulation at 1 kHz (IEC 61000-4-6).

CFI Emission⁽²⁾

0.15 to 30 MHz and 73 dB (µV) QP (EN 50081-2).

RFI Immunity⁽²⁾

Output error of < 5% of span when tested with field strength of 10 V/m from 80 to 1000 MHz with 80% amplitude modulation at 1 kHz (IEC 61000-4-3).

RFI Emission⁽²⁾

30 to 1000 MHz with 47 dB (µV/m) at 10 m (EN 50081-2)

2. All input/output cables must be installed in metallic conduit. Panel mount unit must be installed in metallic enclosure.

High Frequency Transient⁽²⁾

Withstands high frequency transient on ac power line of +/-2 kV, 5 kHz and 5 nS rise time pulses (IEC 61000-4-4).

Lightning Transient⁽²⁾

Withstands surge discharge of +/-4 kV with Tr/Th of 1.2/50 μ S (IEC 61000-4-5).

Electrostatic Discharge⁽²⁾

6 kV contact 8 kV air discharge, Criteria A (IEC 61000-4-2).

Magnetic Field Immunity

30 A (rms)/m at 50/60 Hz (IEC 61000-4-8)(2).

Voltage Dips (ac Power Port)

10 ms at -30% Criteria B and 100 ms at -60% Criteria C (IEC 61000-4-11).

Voltage Interruptions (ac Power Port)

>95% at 5 s, Criteria C (IEC 61000-4-11).

Voltage Fluctuations (ac Power Port)

230 V ac +/-10% and 50 Hz +/-5%, 15 min (IEC SC77A WG6)

Common Mode Rejection Ratio

120 dB, dc; or 50/60 Hz, ac; between loop and sensor (42 V peak maximum)

SYSTEM ACCURACY OF THE 875CR ANALYZER AND AN 871CR SENSOR FOR RESISTIVITY MEASUREMENT

The 875CR Analyzer and 871CR-B.....-R Sensor (shown in Figure 5) combine to produce an advanced resistivity measurement system with significantly enhanced performance. Exceptional stability and performance during measurement in pure and ultrapure water are provided by the above combination. Temperature-compensated system accuracy has been shown to be better than or equal to $\pm 1.06\%$ rms throughout the 20 to 60°C temperature range. All variables – cell factor calibration, design for increased analyzer and sensor accuracy, and calibration procedures – have been refined for optimum performance.

Figure 5. 871CR-B Sensor

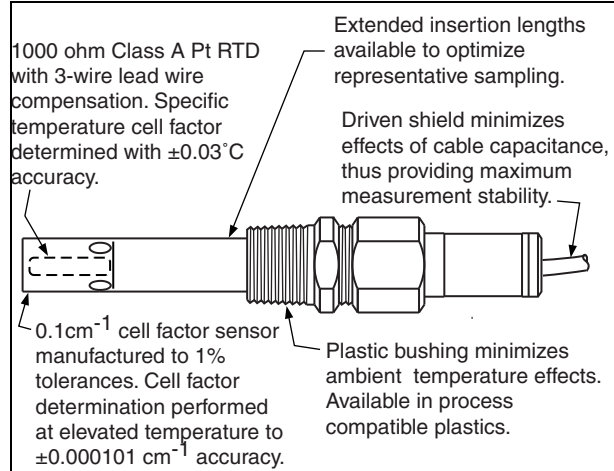

The premium resistivity sensors are manufactured of materials accepted in industries utilizing ultrapure water. They are available with increased insertion lengths and a larger profile to optimize representative measurement sampling. The 0.1cm^{-1} cell factor sensors are manufactured to tolerances of $\pm 1\%$ of nominal, and are precalibrated with an ultrapure water calibration factor determined at elevated temperatures to an accuracy of $\pm 0.000101\text{ cm}^{-1}$. This elevated-temperature, high-purity water calibration has been determined to be the best method for an accurate cell constant calibration because it reduces sensitivity to impurities. The cell factor accuracy of 0.101% assumes published data for ultrapure water which introduces negligible error. If experimental uncertainty in the published data is considered, the effective cell factor accuracy changes to $\pm 0.270\%$, thereby impacting the system accuracy stated above.

With increased use of hot deionized water rinsing for wafer washing and other semiconductor applications, comes the need for higher performance temperature-compensated measurement. The 875CR/871CR-B Analyzer/Sensor combination meets this high-performance need. Figure 6 shows resistivity vs. temperature curves for a range of water samples with salt to ultrapure water ($18.16\text{ M}\Omega\cdot\text{cm}$). Note that, as the temperature of water with trace impurities increases, the absolute resistivity of that water starts to converge to similar values for the various samples. Also, as the temperature increases, the relationship between resistivity and salt concentration becomes smaller; and calculation of the temperature-compensated value at 25°C becomes more demanding.

The combined high analyzer measurement accuracy, cell factor accuracy, and temperature measurement accuracy of the 875CR and 871CR (Analyzer and Sensor) work synergistically to minimize errors associated with the convergence of these curves when compensating resistivity measurements back from elevated temperatures.

Figure 6. Temperature/Resistivity Relationship

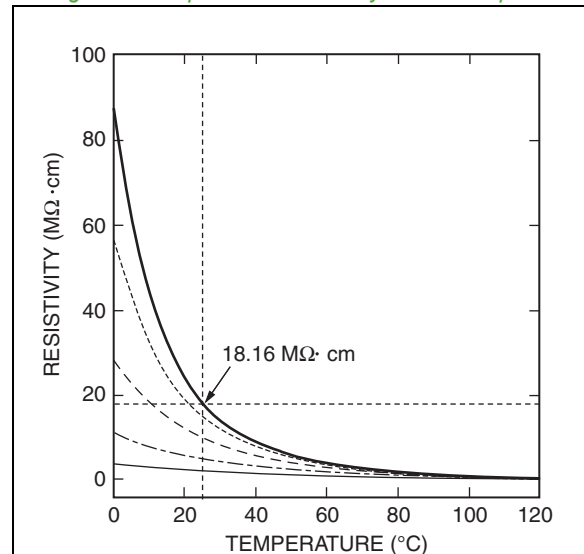

To improve the temperature-corrected resistivity measurement over an extended temperature range, the most important parameter to control is the accuracy of the temperature measurement. The 871CR-B Sensor (see Figure 4) incorporates a Class A 1000 W Pt RTD three-wire temperature transducer for temperature measurement optimization. Platinum RTDs are mechanically and electrically stable with accurately known thermal curves. In addition to an accurate transducer, highly accurate temperature measurements also require lead wire resistance compensation. The 871CR Sensor family incorporates a three-wire resistance measurement and a $1000\ \Omega$ RTD (instead of a $100\ \Omega$ RTD) to minimize lead wire effects. The actual temperature calibration (tCF) of each cell's RTD is known with an accuracy of $\pm 0.03^\circ\text{C}$.

The 875CR is a high performance, intelligent, electrochemical analyzer. A factory default calibration is available for every measurement range selected and the analyzer has a choice of three pre-engineered resistivity-specific temperature compensations available for ultrapure water (based upon published research). The measurement method used to make the absolute resistivity measurement is extremely important to achieve optimum results. The 875CR Analyzer uses the

optimum electrical ac frequency and voltage sine wave for each measurement range chosen. It has an accuracy of 0.1% of full scale chosen to operate and the temperature circuit has an accuracy of $\pm 0.03^\circ\text{C}$.

The two factory sensor calibrations (CF and tCF) are easily entered into the calibration menu of the analyzer for total system calibration.

FUNCTIONAL SPECIFICATIONS

Power Requirements

24, 100, 120, 220, or 240 V ac, 50 or 60 Hz; or 24 V dc.

Power Consumption

17 W maximum

Measurement Ranges

The ranges shown in Table 3 are temperature compensated values. However, the analyzer is able to read 5X (five times) greater conductivity in the absolute (nontemperature compensated) mode of measurement, at reduced accuracy.

Temperature Measurement Ranges

100 Ω Platinum RTD (2 wire)

-20 to $+200^\circ\text{C}$ (-4 to $+392^\circ\text{F}$)

1000 Ω Platinum RTD (3 wire)

-20 to $+200^\circ\text{C}$ (-4 to $+392^\circ\text{F}$)

100 k Ω Thermistor (2 wire)

-20 to $+120^\circ\text{C}$ (-4 to $+248^\circ\text{F}$)

Temperature Compensations

Conductivity

- ▶ Phosphoric Acid (H_3PO_4), 0 to 93°C ; 25°C Reference
- ▶ Low Conductivity (ions + water, or ions with water subtraction); 25°C Reference
- ▶ Acetic Acid (CH_3COOH), 0 to 121°C ;

25 $^\circ\text{C}$ Reference

- ▶ USP23/24 Pharmacopoeia (NH_3/NaCl), 0 to 100°C
- ▶ Ammonia (NH_3), 0 to 100°C ; 25°C Reference
- ▶ Morpholine, 0 to 100°C ; 25°C Reference
- ▶ Dilute NaCl, 0 to 200°C
- ▶ Cation, 0 to 80°C ; 25°C Reference
- ▶ Linear, 0.5 to 5.0% per $^\circ\text{C}$; 25°C Reference
- ▶ Custom, User Programmable
- ▶ Absolute

Resistivity

- ▶ Ultrapure Water with NaCl Impurities. Choice of Algorithms include T Light Published Data (recommended), Foxboro/Light, or Marsh and Stokes Water Dissociation.
- ▶ USP23/24 Pharmacopoeia (NH_3/NaCl)
- ▶ Custom, User Programmable
- ▶ Absolute

Chemical Compensations over Temperature

Phosphoric Acid, 0 to 3%

Acetic Acid, 0 to 9%

Analog Outputs

- ▶ Dual Isolated Outputs
- ▶ Outputs Configurable to:
 - Temperature Compensated Conductivity/Resistivity, Cells 1 and 2
 - Absolute Conductivity/Resistivity, Cells 1 and 2
 - Temperature, Cells 1 and 2
 - % Rejection, Ratio, Average, and Difference
- ▶ 4 to 20 mA Linear Output

- ▶ Analog Output Hold - from 3.8 to 20.5 mA dc
- ▶ Loop Power to support up to 800 Ω of Loop Resistance
- ▶ Analog Output Zero Setting adjustable to 100% of Full Scale Range. Minimum Difference of 5% between Zero and span Ranges
- ▶ Analog Output Programmable to any Value between 3.8 and 20.5 mA, upon Failure.

Analog Output Isolation

Outputs are isolated from earth (ground) and from each other.

Table 3. Measurement Ranges

Units of Measurement	Conductivity Measurement Ranges for a Cell Factor of:	
	0.1 cm ⁻¹	10 cm ⁻¹
μS/cm	1, 2, 5, 10, 20, 50, 100, and 200	200, 500, 1000, 2000, and 5000
mS/cm	0.1, 0.2	0.2, 0.5, 1, 2, 5, 10, and 20
mS/m	0.1, 0.2, 0.5, 1, 2, 5, 10, and 20	10, 20, 50, 100, 200, 500, 1000, and 2000
S/m	Not Applicable	0.1, 0.2, 0.5, 1, and 2
Percent (%) Concentration	Not Applicable	0 to 3% H ₃ PO ₄ 0 to 9% CH ₃ COOH
Units of Measurement	Resistivity Measurement Ranges for a Cell Factor of:	
	0.1 cm ⁻¹	10 cm ⁻¹
MΩ•cm	0.1, 0.2, 0.5, 1, 2, 5, 10, and 20	Not Applicable
KΩ•cm	50, 100, 200, 500, 1000, 2000, and 5000	0.5, 1, 2, 5, 10, 20, 50, 100, and 200

Minimum Output Span (Measurement)

5% of full scale

Maximum Output Span (Measurement)

500% of full scale

Isolated Output Load

800 Ω, maximum

Digital Inputs

For PLC based control, 3 digital inputs are standard, each corresponding to a specific application (#1, #2, #3) configured in the analyzer. Each application may have unique range, units, outputs, temperature compensation, and alarms. Remote range switching can thus be controlled by a PLC for applications where the sensor will encounter fluids of varying conductivity levels (e.g., low, medium, or high).

Specifications for Digital Inputs/Outputs

- ▶ Terminal DV+ power: 4.5 V ±3% at 10 mA max.
- ▶ Terminal DV- power: -20 V +1.0% at 10 mA max.

Above voltages are provided by the 875 analyzer.

- ▶ Digital Inputs 1 through 4
 - High Logic: User must ensure voltage to be between 2.7 and 10 V
 - Low Logic: User must ensure circuit to be open, or less than 0.8 V
 - Digital inputs are only to be used with the +4.5 V/-20 V outputs provided by the Foxboro 875 analyzer.

Contact Global Customer Support for sample wiring schemes.

Standard Digital Communications

RS-232C digital communications port for remote configuration and calibration via a user's PC. Configurator Utility Software option "-F" is offered for use with the PC (see Model Code section).

Optional Digital Communications

HART Communication Protocol.

Sensor Cell Factor

In addition to the standard cell factors of 0.1 cm⁻¹ and 10 cm⁻¹ for 871CR and 871CC Series Sensors, the analyzer is user-programmable for cell factors between 0.0001 and 99.999 cm⁻¹ to allow for compatibility with special and/or other sensors. For these applications, the total external input resistance must be between 100 Ω and 8 MΩ .

Precalibrated Measurement Ranges

In addition to the customer-specified calibrations, the analyzer is factory calibrated for every measurement range included in its program. Recalibration is simply a matter of reconfiguring the analyzer (pushing a few buttons) for the desired calibrated measurement range. No external hookup (resistors, etc.) is required.

Sensor Compatibility

The analyzer is compatible with Foxboro 871CR Series Sensors and 871CC Series Sensors. For best performance, the 871CR Series Sensor is recommended. See System Accuracy Specifications when analyzer is used with an 871CR-B Sensor.

Alarms

Two configurable alarms can be independently set as high or low alarms based on the primary measurement, input temperature, or a diagnostic.

Each alarm is configurable for the following:

- ▶ Differential - Measurement and Temperature
- ▶ % Rejection
- ▶ Ratio
- ▶ Average
- ▶ Diagnostic Fault, Freely Programmable

Adjustable hysteresis for both alarms is 0 to 100% of full scale. Feed, delay, and trigger times are adjustable from 0 to 99.99 minutes.

Alarm Outputs

Mechanical Relay – Two independent, isolated, Form "C" contacts rated 2 A at 24 V dc, 5 A at 250 V ac, noninductive. With ATEX and IEC certifications the ratings are 2 A at 30 V dc and 5 A at 160 V ac. Inductive loads, such as a motor or solenoid, can be driven with external surge absorbing devices across contact terminations. Contacts are not powered by the 875 Analyzer.

Displayed Data

Each of the two lines of the display area can be configured to present:

- ▶ Temperature Compensated Conductivity/Resistivity, Cells 1 and 2
- ▶ Absolute Conductivity/Resistivity, Cells 1 and 2
- ▶ Temperature, Cells 1 and 2
- ▶ % Rejection
- ▶ Ratio
- ▶ Measurement Average
- ▶ Measurement Difference
- ▶ Temperature Difference
- ▶ Analog Output, Cells 1 and 2
- ▶ Scan Mode - any of the above Parameters at adjustable Viewing Cycles

Data Storage

Configuration, calibration, and operating parameters stored in nonvolatile memory for >5 years.

Measurement Display Units

μS/cm, mS/cm, S/m, mS/m, kΩ•cm, MΩ•cm, %, °C, °F, mA, g/L, oz/gal, ppt (parts per thousand), and ppm (parts per million)

- ▶ Temperature Compensated Conductivity/Resistivity, Cells 1 and 2
- ▶ Absolute Conductivity/Resistivity, Cells 1 and 2
- ▶ Temperature, Cells 1 and 2

Measurement Damping

Adjustable to None, 5, 10, 20, 40, or 120 seconds, where None is the analyzer base response time.

Firmware Download

Analyzer's operating firmware is downloadable to Analyzer via the RS-232 serial communication port using a utility executed on the user's PC. See Model Code Optional Selection "-F"; Windows-based Configurator Utility Software.

Operating Modes

- ▶ On-Line Measurement – Continuously outputs measurement data to front panel display and serial communication port
- ▶ On-Line Status – Provides current information
- ▶ Off-Line Calibration – Ability to calibrate analyzer full scale for primary measurements and temperature
- ▶ Off-Line Configuration – User can configure all ranges, units of measure, alarms, analog outputs, and other parameters
- ▶ Hold

Background Self-Diagnostics

ANALYZER

- ▶ Checksum and EEPROM on Power Up
- ▶ Code Space Checksum and CRC on Power Up, and approximately every 5 minutes thereafter
- ▶ Stack Checking - Continuous
- ▶ Watchdog Timer - Continuous

SENSOR

- ▶ Automatic Temperature Compensator Open
- ▶ Automatic Temperature Compensator Short
- ▶ Liquid Leakage into Sensor

OTHER

- ▶ 4 to 20 mA Output Out-of-Range
- ▶ Temperature Compensation Out-of-Range
- ▶ Measurement Out-of-Range

Logbook Function (Also see Previous "History Log" Section)

Events such as warning messages, calibrations, and configuration activity stored in nonvolatile memory. Time-of-day and date stamped with each stored event. Storage accommodates 100 events.

ELECTRICAL SAFETY SPECIFICATIONS

Testing Laboratory, Type of Protection, and Area Classification	Application Conditions (a)	Electrical Safety Design Code
ATEX Ex protection 'n' for Zone 2; II 3 G EEx nC [L], IIC (c).	Temperature Class T4 where $20^{\circ}\text{C} \leq T_a$ to a maximum ambient temperature of 60°C (140°F). See certificate KEMA 02ATEX1329X.	N
CSA ordinary locations.	For panel mounted units, see note (b).	C
CSA for Class I, Division 2, Groups A, B, C, and D; Class II, Division 2, Groups F and G; and Class III, Division 2 hazardous locations.	Temperature Class T4. For panel mounted units, see note (b).	
FM ordinary locations.	For panel mounted units, see note (b).	F
FM nonincendive for Class I, Division 2, Groups A, B, C, and D; Class II, Division 2, Groups F and G; and Class III, Division 2 hazardous locations.	Temperature Class T4. For panel mounted units, see note (b).	
IECEx protection 'n' for Zone 2; Ex nA nL nC [nL] IIC.	Temperature Class T4 at maximum ambient temperature of 60°C (140°F).	D
UL ordinary locations.	---	U

- a. Specifications for the analyzers may differ from standard specifications. Refer to MI 611-206 for CSA and FM specifications, entity parameters, and special conditions of use. And refer to MI 611-208 for ATEX specifications, entity parameters, and special conditions of use.
- b. Panel-mounted unit must be installed as follows:
For Ordinary and Class I, Division 2 locations: install in a protective enclosure to prevent access to live parts.
For Class II and Class III Division 2 locations: install in a dusttight enclosure.
- c. The L means that the unit contains energy limited circuits to the sensor.

NOTE

The enclosures above must meet the ingress protection level required by the application, up to NEMA 4X or IP65.

PHYSICAL SPECIFICATIONS

Analyzer Enclosure

For Panel Mounting

The housing is made of Noryl plastic. The basic housing meets NEMA 1 requirements for general purpose, indoor applications. However, when installed in a panel, the front surface is protected by a gasketed, epoxy-painted, die cast, low copper aluminum bezel. This provides the front surface with the environmental and corrosion resistant protection of NEMA Type 4X, CSA Encl. 4X, and IEC IP65.

For Field Mounting

The enclosure (housing, front bezel, and cover) is made from a die cast, low copper, aluminum alloy protected with an epoxy paint finish. The entire enclosure assembly provides the environmental and corrosion resistant protection of NEMA Type 4X, CSA Encl. 4X, and IEC IP65.

Analyzer Mounting

The analyzer enclosure can be mounted to a panel, or field mounted to a surface or nominal DN 50 or 2-in pipe. When field mounted, a painted, low carbon steel bracket and a kit of mounting hardware is provided. See “Dimensions-Nominal” section.

Sensor Cable Length

33 m (100 ft) maximum

Electrical Connections

Panel Mounted Enclosure

Terminals for the field wiring are provided at the rear, stepped surfaces of the housing. The terminals are directly accessible without removing any cover(s). See “Dimensions-

Nominal” section.

Field Mounted Enclosure

Terminals are provided within the lower enclosure compartment. Field wires enter through holes in the bottom of the enclosure sized to provide for wiring conduit or cable glands. An easily removable bottom front cover, with captive screws, protects the field wiring compartment. See “Dimensions-Nominal” section.

Approximate Mass

Panel Mounted Enclosure

1.8 kg (4 lb)

Field Mounted Enclosure

3.3 kg (7.3 lb)

Wiring Terminal Configuration, Designation, and Description

Figure 7 shows the terminal configuration and designation for both the panel and field mounted enclosures. Table 4 describes the use for each terminal.

Figure 7. Wiring Terminal Configuration and Designation

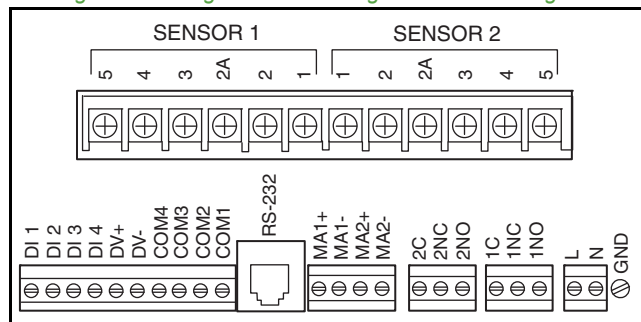

Table 4. Wiring Terminal Designation and Description

Sensor 1 and Sensor 2 Connections		
871CR Sensor Terminal	Terminal Description	871CC Sensor Terminal
1	Outer Electrode	1
2	Inner Electrode	2
2A	Shield (Screen)	Not Used
3	RTD Drive	3
4	RTD Return	4
5	RTD Cable Length Compensation	Not Used
Digital, Analog, Alarm, and Power Connections		
DI 1, 2, 3, 4	Digital Inputs	
DV+, DV-	Power Source for Digital Inputs	
COM 1, 2, 3, 4	Digital I/O Communications	
MA1+, MA1-	Analog Output 1	
MA2+, MA2-	Analog Output 2	
1C, 1NC, 1NO	Alarm 1	
2C, 2NC, 2NO	Alarm 2	
L	Power, Line (Black)	
N	Power, Neutral (White)	
GND	Power, Ground (Green)	

OPTIONAL FEATURES AND ACCESSORIES

Option -A: Storm Door

This plexiglas door is attached to the front surface of the enclosure and hinges upward. It is used to prevent accidental or inadvertent actuation of front panel controls, and also useful in dusty or hose down environments, particularly in field mounting applications. The door is clear plastic to allow viewing of the display when closed, and also hinged to allow ready access to front panel controls. Specify Optional Selection “-A”

Option -F: Configurator Utility

The configurator utility is a software package for use with a Windows-based computer terminal. Use of this Windows-based software package allows remote configuration and calibration with the user’s PC. Specify Optional Selection “-F”

Option -C: Digital HART Communications Protocol

HART protocol replaces the secondary 4 to 20 mA measurement output signal. It operates using the frequency shift keying (FSK) principle. Measurements and diagnostics are available from the HART Communicator connected to the two-wire loop (carrying the 4 to 20 mA output signal) by using a bidirectional digital signal superimposed on the 4 to 20 mA current signal. Simultaneous analog and digital communications is thus provided without interrupting (or disturbing) any analog signal transmission that might be occurring. Both a Communicator and a PC-Based Configurator may be connected to each HART loop (see Figure 8). A minimum resistance of 250 ohms must be available in the communication circuit. Two measurement updates per second are communicated. Also, with

HART communication, up to fifteen analyzers in a multidrop configuration can be connected on a single twisted pair of wires, or over leased telephone lines (see Figure 9). Specify Optional Selection “-C” for HART Protocol.

Options -N and -P: Rugged Construction

Rugged construction is offered with Options -N and -P. These options are only available with the 120 V ac Analyzer, and require the selection of the reinforced mounting bracket (Enclosure Mounting Selection 4). The rugged construction design allows hard mounting of the analyzers for Navy shipboard installations without performance degradation. They have been vibration tested per MIL Standard 167-1, and mechanical shock tested per MIL Standard 901, Grade A, Class I, Type C.

Figure 8. Point-to-Point Communications 4 to 20 mA Output with HART

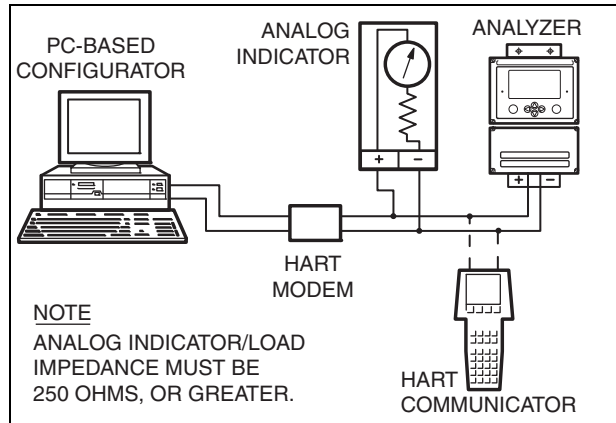
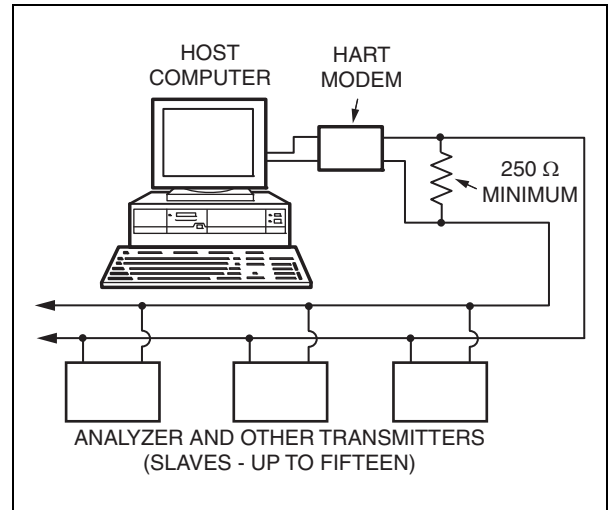

Figure 9. Typical Multidrop Configuration 4 to 20 mA Output with HART



MODEL CODE

<u>Description</u>	<u>Model</u>
Contacting Conductivity and Resistivity Intelligent Electrochemical Analyzer	875CR
<u>Supply Voltage and Frequency</u>	
120 V ac, 50 or 60 Hz (c)	-A
220 V ac, 50 or 60 Hz	-B
240 V ac, 50 or 60 Hz	-C
24 V ac, 50 or 60 Hz	-E
100 V ac, 50 or 60 Hz	-J
24 V dc (a)	-D
<u>Enclosure Mounting</u>	
Panel Mounting - Standard Construction (b)	1
Field Mounting to a DN50 or 2-in Pipe - Standard Construction	2
Field Mounting to a Surface, with standard mounting bracket - Standard Construction	3
Field Mounting to a Surface, with reinforced standard mounting bracket - Rugged Construction	4
<u>Electrical Safety (also see “Electrical Safety Specifications” section)</u>	
ATEX Protection “n” for Zone 2; II 3 G; EEx nC [nL] IIC	N
CSA, Ordinary and Division 2 Locations, NI (b)	C
FM, Ordinary and Division 2 Locations, NI (b)	F
IECEx protection n for Zone 2; Ex nA nL nC [nL] IIC	D
UL (Underwriter’s Laboratory) Ordinary Locations	U
<u>Optional Selections</u>	
Storm Door	-A
Digital HART Communication and 4 to 20 mA Output	-C
Configurator Utility (Windows-based Software)	-F
Rugged Construction, shock and vibration, with 4 to 20 mA Analyzer Outputs (c)	-N
Rugged Construction, shock and vibration, with 0 to 10 V Analyzer Outputs (c)	-P
Example: 875CR-A3F-A; 875CR-B2C-AC	

- a. The 24 V dc power selection provides a volts dc four-wire analyzer (it is not a loop powered 4 to 20 mA device).
- b. Panel mounted unit must be installed as follows:
For Ordinary, and Class I, Division 2 locations: install in a protective enclosure to prevent accessibility to live parts.
For Class II, and Class III, Division 2 locations: install in a dusttight enclosure.
- c. The rugged construction options -N and -P are available only with:
 - Supply voltage Code -A (120 V ac, 50 or 60 Hz)
 - Enclosure Mounting Code 4 (field-mounted enclosure with reinforced mounting bracket).

NOTE

The enclosures above must meet the ingress protection level required by the application, up to NEMA 4X or IP65.

DIMENSIONS NOMINAL

mm
in

PANEL MOUNTED ENCLOSURE

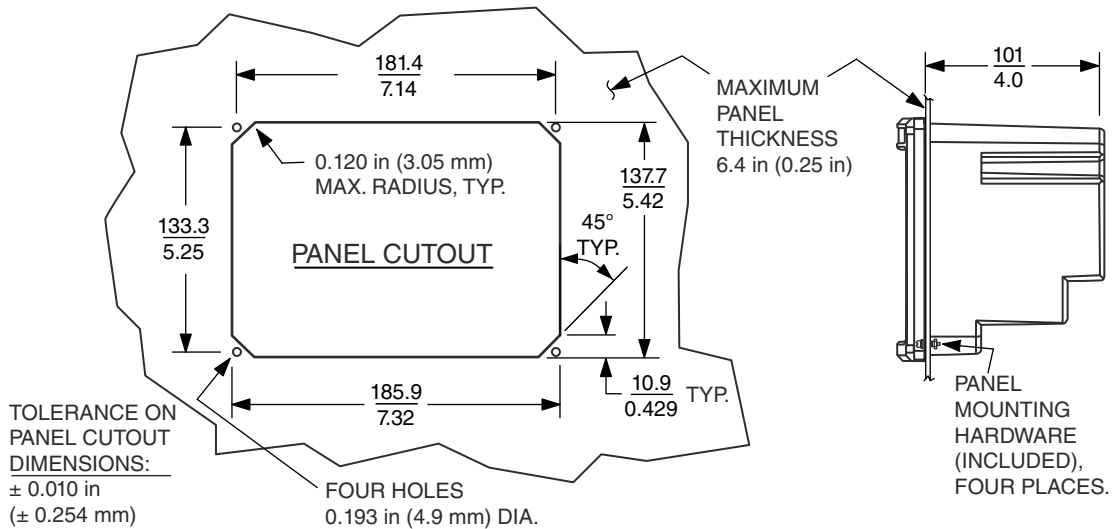
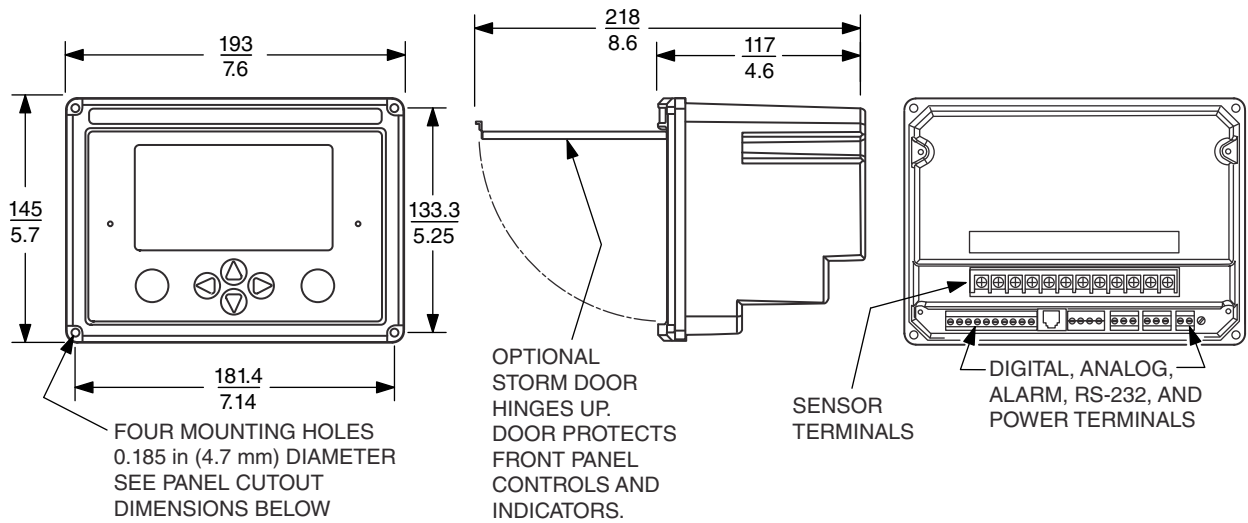

mm
in

FIELD MOUNTED ENCLOSURE
(SEE NEXT PAGE FOR ENCLOSURE MOUNTED TO A SURFACE AND PIPE)

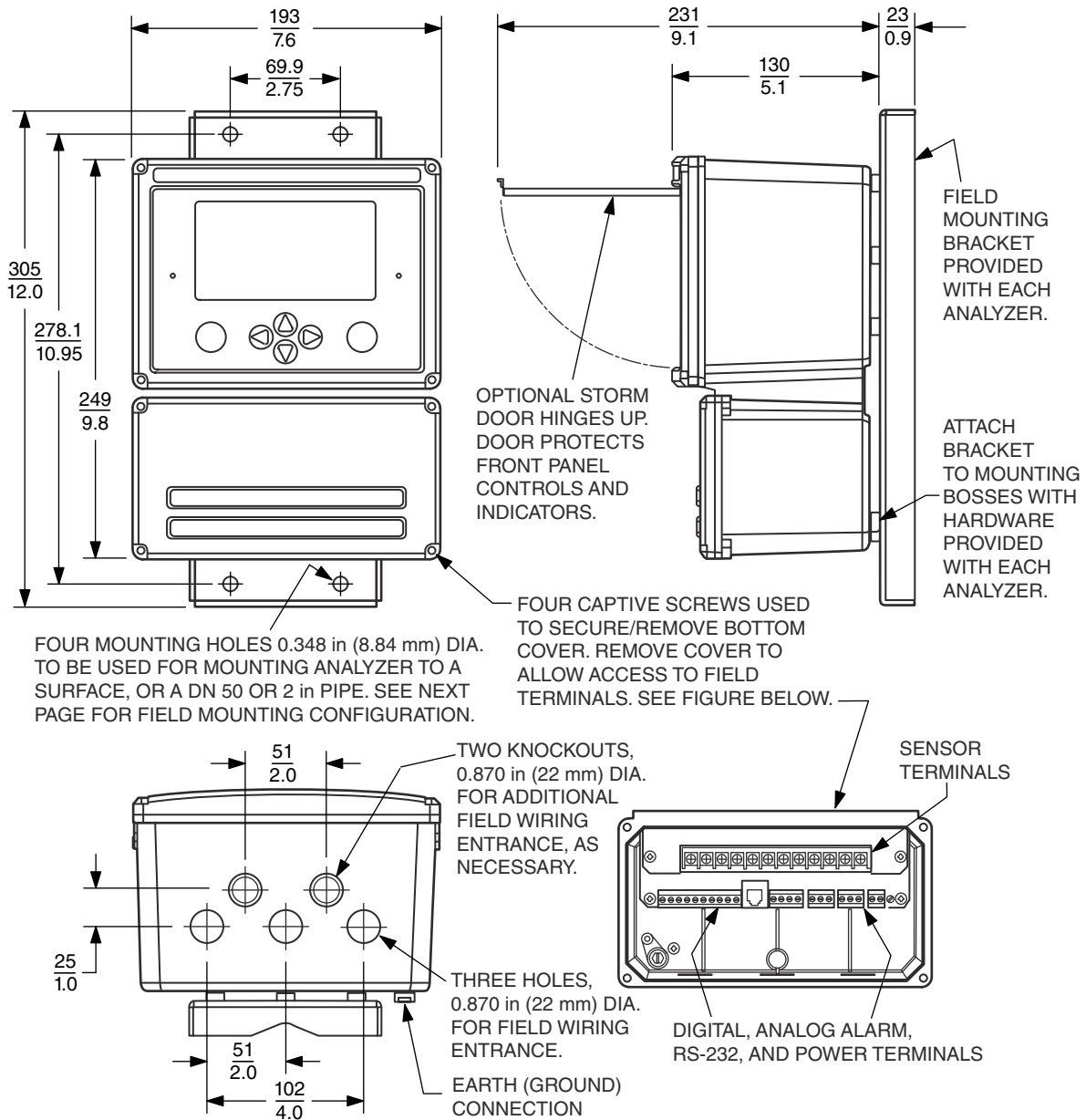

mm
in

SURFACE MOUNTED ENCLOSURE

USE APPROPRIATE
HARDWARE TO FASTEN
BRACKET TO MOUNTING
SURFACE

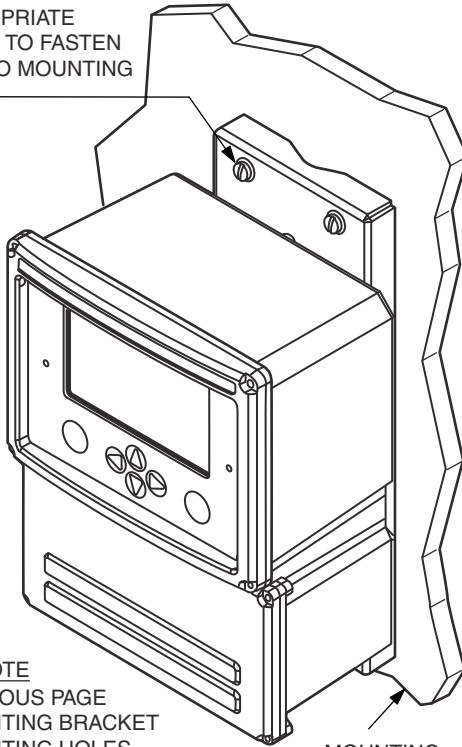

NOTE
SEE PREVIOUS PAGE
FOR MOUNTING BRACKET
AND MOUNTING HOLES
DIMENSIONAL DATA

MOUNTING
SURFACE

PIPE MOUNTED ENCLOSURE

PIPE MOUNTING KIT
(U-BOLTS, WASHERS,
AND NUTS)

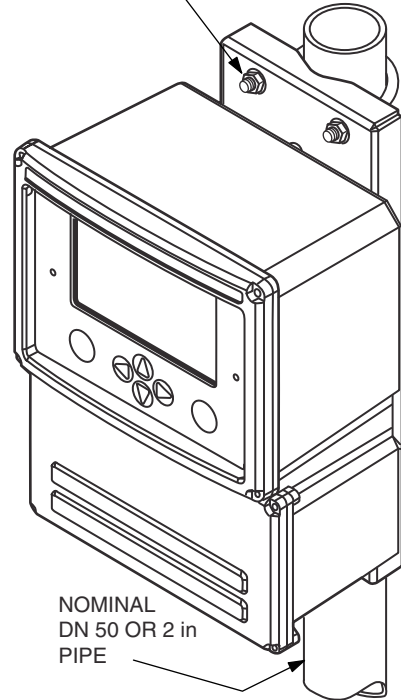

NOMINAL
DN 50 OR 2 in
PIPE

NOTES

ORDERING INSTRUCTIONS

1. Model Number
2. Sensor Cell Factor (0.1 or 10 cm⁻¹), Channel 1 and Channel 2
3. Measurement Range and Units, Channel 1 and Channel 2
4. Temperature Compensation Type, Channel 1 and Channel 2
5. Analog Output Range, Channel 1 and Channel 2
6. Temperature Compensation Input, Channel 1 and Channel 2
 - All 871CR use 1000 W RTD, 3-wire
 - 871CC-A through -G use 100 kW Thermistor
 - 871CC-K through -M use 100 W RTD, 2-wire
7. User Tag and Application

REFERENCE DOCUMENTS

Document Number	Document Description
PSS 6-3C2 A	871CC Contacting Connectivity and Resistivity Sensors and Accessories
PSS 6-3C2 B	871CR Contacting Connectivity and Resistivity Sensors and Accessories
MI 611-206	Intrinsic Safety Connector Diagrams - FM, CSA, and IECEx
MI 611-208	Electrochemical Products Product Safety Information - ATEX
MI 611-222	Intelligent Electrochemical Analyzer for Contacting Connectivity and Resistivity Measurements

OTHER FOXBORO PRODUCTS

The Foxboro product lines offer a broad range of measurement and instrument products, including solutions for pressure, flow, analytical, temperature, positioning, controlling, and recording.

For a list of these offerings, visit our web site at:

www.fielddevices.foxboro.com